

Idler wheels

Example of application

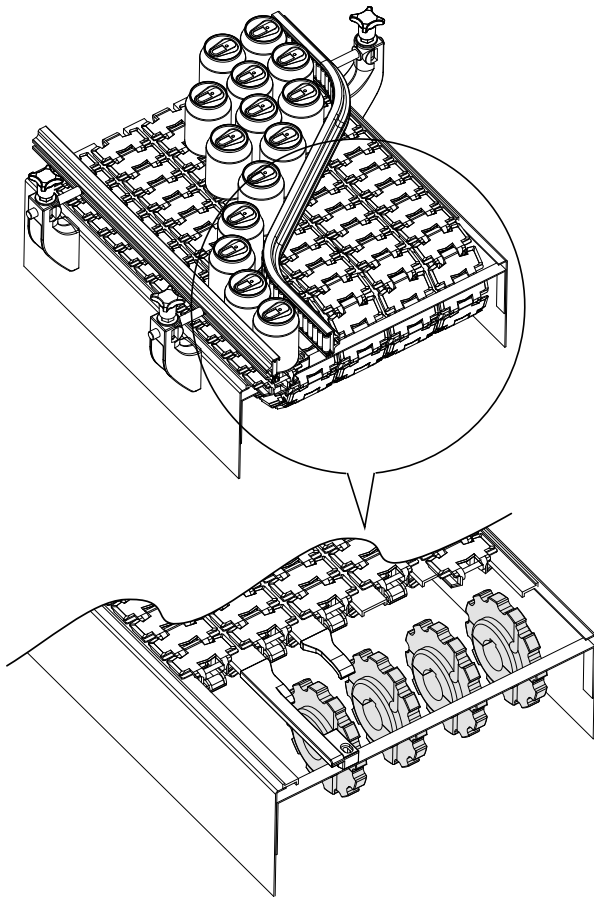

Split sprocket 12 teeth

(machined, for chains series 879, 879 TAB, 880, 880 TAB)

Part. **587**

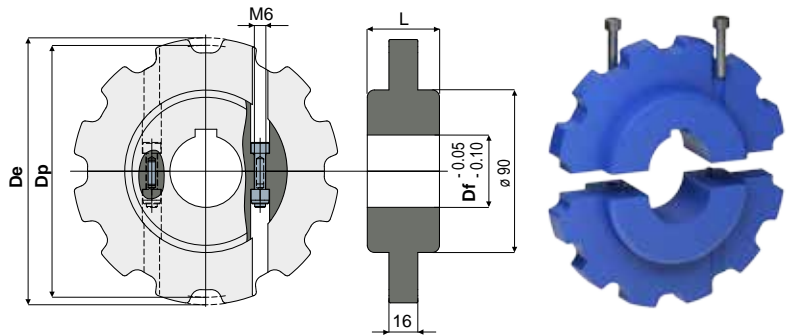

L = 40			
Df (mm)	Dp (mm)	De (mm)	Code
25	147,2	145,8	587 / 90977
30	147,2	145,8	587 / 90978
35	147,2	145,8	587 / 90979
40	147,2	145,8	587 / 90980

L = 42,5			
Df (mm)	Dp (mm)	De (mm)	Code
25	147,2	145,8	587 / 91378
30	147,2	145,8	587 / 91379
35	147,2	145,8	587 / 91380
40	147,2	145,8	587 / 91381

MATERIALS: Wheel made of polyamide blue Ral 5005 colour; screws made of stainless steel AISI 304, nuts in nickel plated brass.

FEATURES: Dimensions of the keyway UNI 6604-69 - DIN 6885/1. 6885/1. To be used with chains Part.710, 711, 713.

BOX QUANTITY: 8 pieces.

ON REQUEST:

- Wheels: With 18 mm. hole diameter to be machined.
- Wheels: In polyamide blue Ral 5005 FDA APPROVED.
- Box quantity: According to your request.

Split idler wheel 12 teeth

(machined, for chains series 879, 879 TAB, 880, 880 TAB)

Part. **586**

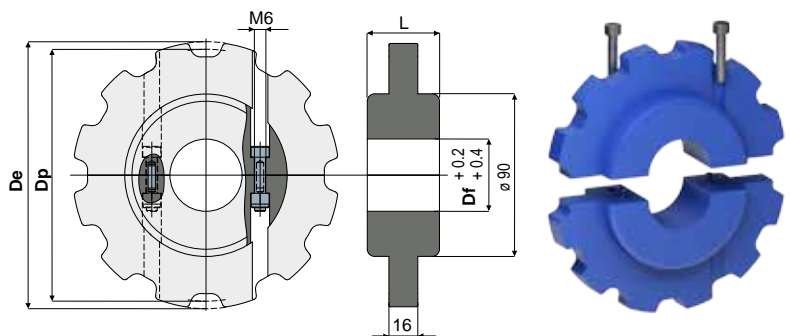

L = 40			
Df (mm)	Dp (mm)	De (mm)	Code
25	147,2	145,8	586 / 90973
30	147,2	145,8	586 / 90974
35	147,2	145,8	586 / 90975
40	147,2	145,8	586 / 90976

L = 42,5			
Df (mm)	Dp (mm)	De (mm)	Code
25	147,2	145,8	586 / 91374
30	147,2	145,8	586 / 91375
35	147,2	145,8	586 / 91376
40	147,2	145,8	586 / 91377

MATERIALS: Wheel made of polyamide blue Ral 5005 colour; screws made of stainless steel AISI 304, nuts in nickel plated brass.

FEATURES: To be used with chains Part.710, 711, 713.

BOX QUANTITY: 8 pieces.

ON REQUEST:

- Wheels: With 18 mm. hole diameter to be machined.
- Wheels: In polyamide blue Ral 5005 FDA APPROVED.
- Box quantity: According to your request.