

Idler wheels

Part. 581 Split sprocket 25 teeth (machined, for chains series 821)

NEW

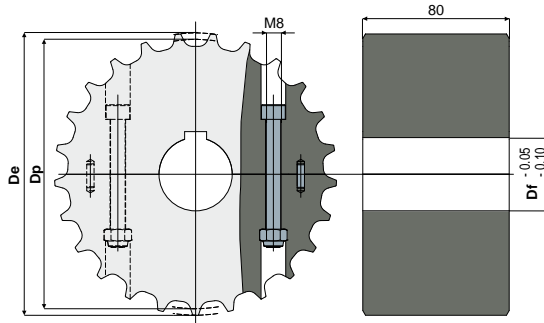

| Df (mm) | Dp (mm) | De (mm) | Code |
|---------|---------|---------|-------------|
| 25 | 153,2 | 153,9 | 581 / 90953 |
| 30 | 153,2 | 153,9 | 581 / 90954 |
| 35 | 153,2 | 153,9 | 581 / 90955 |
| 40 | 153,2 | 153,9 | 581 / 90956 |

MATERIALS: Wheel made of polyamide blue Ral 5005 colour; screws made of stainless steel AISI 304, nuts in nickel plated brass.

FEATURES: Dimensions of the keyway UNI 6604-69 - DIN 6885/1.

BOX QUANTITY: 8 pieces.

ON REQUEST:

- Wheels: With 18 mm. hole diameter to be machined.
- Wheels: In polyamide blue Ral 5005 FDA APPROVED.
- Box quantity: According to your request.

Example of application

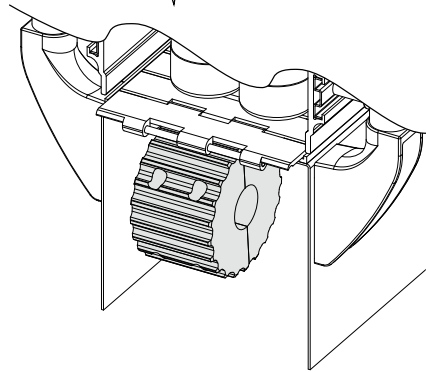
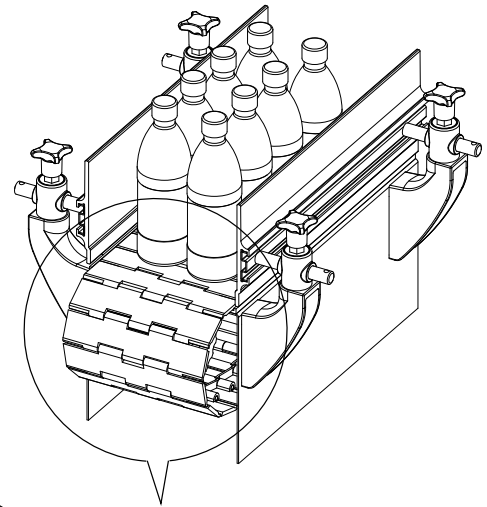

Part. 580 Split idler wheel 25 teeth (machined, for chains series 821)

NEW

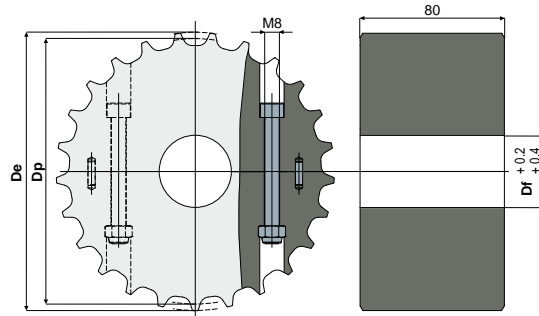

| Df (mm) | Dp (mm) | De (mm) | Code |
|---------|---------|---------|-------------|
| 25 | 153,2 | 153,9 | 580 / 90949 |
| 30 | 153,2 | 153,9 | 580 / 90950 |
| 35 | 153,2 | 153,9 | 580 / 90951 |
| 40 | 153,2 | 153,9 | 580 / 90952 |

MATERIALS: Wheel made of polyamide blue Ral 5005 colour; screws made of stainless steel AISI 304, nuts in nickel plated brass.

BOX QUANTITY: 8 pieces.

ON REQUEST:

- Wheels: With 18 mm. hole diameter to be machined.
- Wheels: In polyamide blue Ral 5005 FDA APPROVED.
- Box quantity: According to your request.