

Idler wheels

Part. **593** **Split sprocket 12 teeth**
(machined, for chains series 882, 882 TAB)

NEW

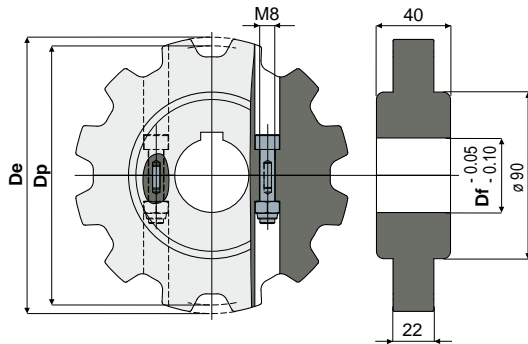

Df (mm)	Dp (mm)	De (mm)	Code
25	147,2	147,6	593 / 91001
30	147,2	147,6	593 / 91002
35	147,2	147,6	593 / 91003
40	147,2	147,6	593 / 91004

MATERIALS: Wheel made of polyamide blue Ral 5005 colour; screws made of stainless steel AISI 304, nuts in nickel plated brass.

FEATURES: Dimensions of the keyway UNI 6604-69 - DIN 6885/1.

BOX QUANTITY: 8 pieces.

ON REQUEST:

- Wheels: With 18 mm. hole diameter to be machined.
- Wheels: In polyamide blue Ral 5005 FDA APPROVED.
- Box quantity: According to your request.

Example of application

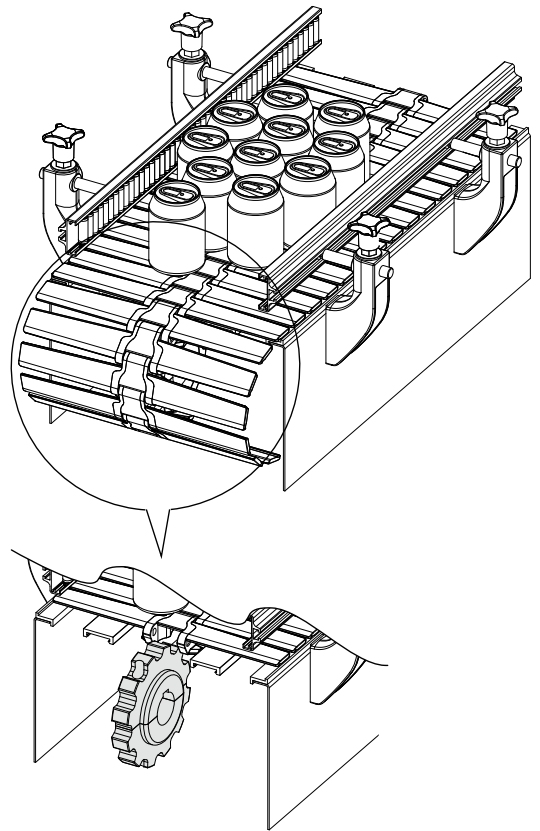

Part. **592** **Split idler wheel 12 teeth**
(machined, for chains series 882, 882 TAB)

NEW

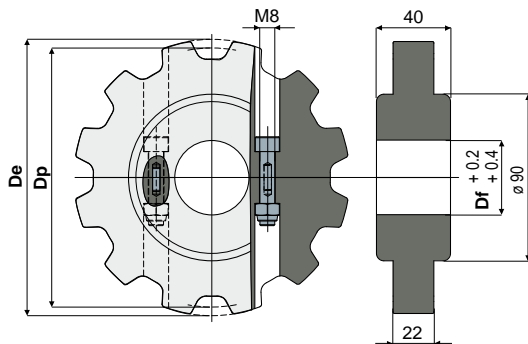

Df (mm)	Dp (mm)	De (mm)	Code
25	147,2	147,6	592 / 90997
30	147,2	147,6	592 / 90998
35	147,2	147,6	592 / 90999
40	147,2	147,6	592 / 91000

MATERIALS: Wheel made of polyamide blue Ral 5005 colour; screws made of stainless steel AISI 304, nuts in nickel plated brass.

BOX QUANTITY: 8 pieces.

ON REQUEST:

- Wheels: With 18 mm. hole diameter to be machined.
- Wheels: In polyamide blue Ral 5005 FDA APPROVED.
- Box quantity: According to your request.