

# Idler wheels

## Part. 455 Split idler wheel 10 teeth (for chains series 879, 879 TAB, 880, 880 TAB)

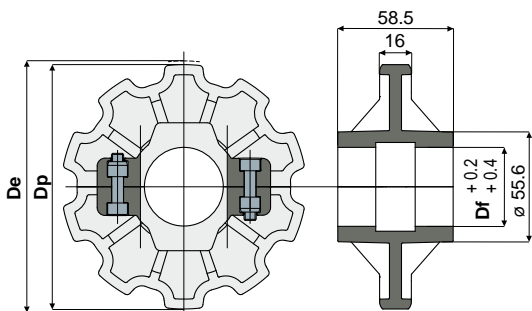

Df (mm)	Dp (mm)	De (mm)	Code
25	123,3	122,5	455 / 85420
30	123,3	122,5	455 / 85421
35	123,3	122,5	455 / 85422
40	123,3	122,5	455 / 85423

**MATERIALS:** Wheel made of polyamide black colour; screws made of stainless steel AISI 304, nuts in nickel plated brass.

**FEATURES:** To be used with chains Part. 710, 711, 713.

**BOX QUANTITY:** 8 pieces.

**ON REQUEST:**

- Wheels: In other materials.
- Box quantity: According to your request.

## Part. 454 Split sprocket 10 teeth (for chains series 879, 879 TAB, 880, 880 TAB)

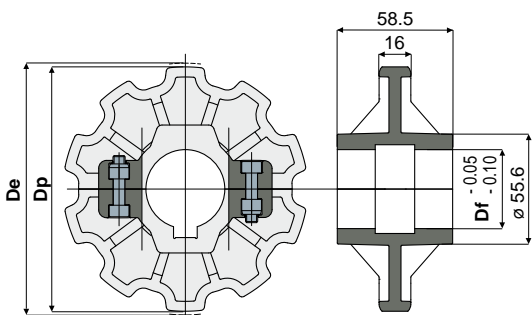

Df (mm)	Dp (mm)	De (mm)	Code
25	123,3	122,5	454 / 85416
30	123,3	122,5	454 / 85417
35	123,3	122,5	454 / 85418
40	123,3	122,5	454 / 85419

**MATERIALS:** Wheel made of reinforced polyamide black colour; screws made of stainless steel AISI 304, nuts in nickel plated brass.

**FEATURES:** Dimensions of the keyway UNI 6604-69 - DIN 6885/1.

To be used with chains Part. 710, 711, 713.

**BOX QUANTITY:** 8 pieces.

**ON REQUEST:**

- Wheels: In other materials.
- Box quantity: According to your request.

### Example of application

