

# Idler wheels

Example of application

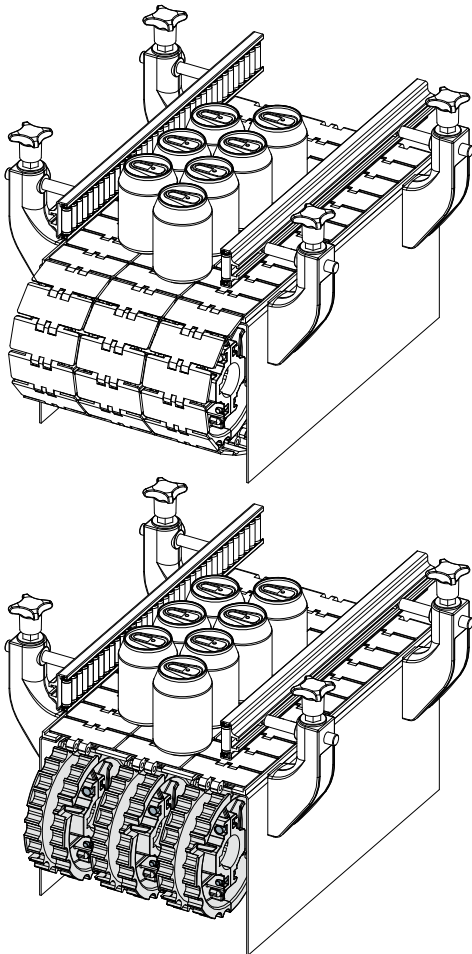

## Split idler wheel 21 teeth (for chains series 815, 820, 831)

Part. **542**

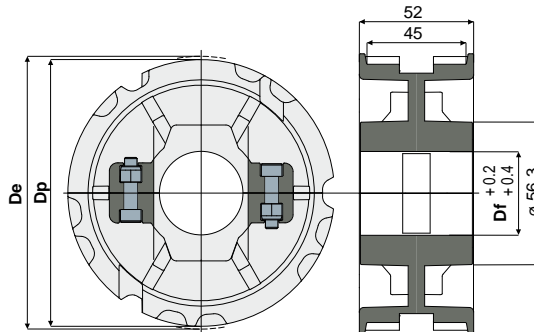

**NEW**

Df (mm)	Dp (mm)	De (mm)	Code
25	129,3	128	542 / 89129
30	129,3	128	542 / 89131
35	129,3	128	542 / 89133
40	129,3	128	542 / 89134

**MATERIALS:** Wheel made of polyamide black colour; screws made of stainless steel AISI 304, nuts in nickel plated brass.

**BOX QUANTITY:** 8 pieces.

**ON REQUEST:**

- Wheels: In other materials.
- Box quantity: According to your request.

## Split sprocket 21 teeth (for chains series 815, 820, 831)

Part. **543**

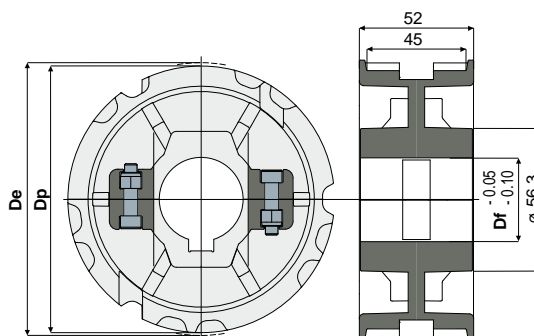

**NEW**

Df (mm)	Dp (mm)	De (mm)	Code
25	129,3	128	543 / 89135
30	129,3	128	543 / 89136
35	129,3	128	543 / 89137
40	129,3	128	543 / 89138

**MATERIALS:** Wheel made of reinforced polyamide black colour; screws made of stainless steel AISI 304, nuts in nickel plated brass.

**FEATURES:** Dimensions of the keyway UNI 6604-69 - DIN 6885/1.

**BOX QUANTITY:** 8 pieces.

**ON REQUEST:**

- Wheels: In other materials.
- Box quantity: According to your request.