

Articulated feet

(base in reinforced polyamide)

∅ 30 Part. **118**

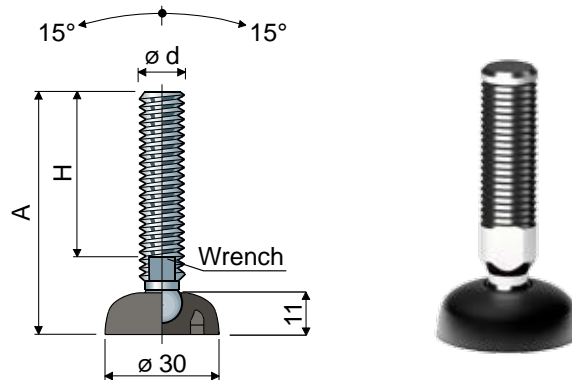

Spindle measures in mm				Spindle material			
∅ d	A	H	Wrench	Zinc plated steel	Stainless steel AISI 304	Stainless steel AISI 316	Max static load (N)
				Code	Code	Code	
M8x1,25	65	45	6	118 / 84270	118 / 84271	-	9000
	85	65	6	118 / 84272	118 / 84273	-	
M10x1,5	57	35	8	118 / 84274	118 / 84275	-	10000
	92	70	8	118 / 84276	118 / 84277	-	
	137	115	8	118 / 84278	118 / 84279	-	
M12x1,75	67	43	10	118 / 84280	118 / 84281	-	11000
	87	63	10	118 / 84282	118 / 84283	-	
	102	77	10	118 / 84284	118 / 84285	-	
	117	93	10	118 / 84286	118 / 84287	118 / 85116	
	147	123	10	118 / 84288	118 / 84289	-	

Spindle measures in inches				Spindle material		
∅ d	A	H	Wrench	Zinc plated steel	Stainless steel AISI 304	Max static load (N)
				Code	Code	
1/2"-13 UNC	5,08"	4"	7/16"	118 / 85170	118 / 85140	11000

Base material: Reinforced polyamide black colour.

Box quantity: 24 pieces.

Accessories

Anti-slip pads:

- code: 84290;
- material: thermoplastic rubber 68 Shore black colour;
- box quantity: 24 pieces.

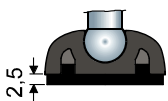

Washers UNI 6592-69 - Box quantity: 24 pieces.

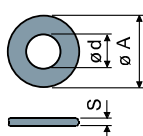

∅ M	M8	M10	M12
Smm	1,6	2	2,5
∅ A mm	17	21	24
Zinc plated steel codes	7636	7283	7284
Stainless steel codes	7637	7286	7287

Nuts UNI 5588-65 - Box quantity: 24 pieces.

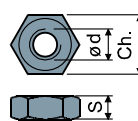

∅ d	M8	M10	M12
Smm	6,5	8	10
Ch. mm	13	17	19
Zinc plated steel codes	7634	7269	7270
Stainless steel codes	7635	7272	7273

On request

- Bases: In reinforced polypropylene (maximum static load is reduced to 1/3 compared to that with polyamide base) • other colours.
- Spindles with: Sunk hexagon head • second wrench seat head • hexagon wrench seat • threads with other pitches and lengths.
- Box quantity: Not standard.
- Assembling of: Anti-slip pads • nuts • washers.

Thread sizes in inches are expressed as the number of threads (UNC coarse thread) per Imperial inch