

Articulated feet

(base in reinforced polyamide)

60X95 Part. 27

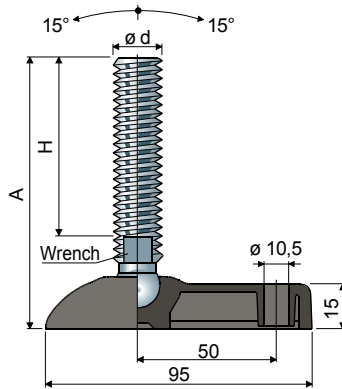

Spindle measures in mm				Spindle material			
ød	A	H	Wrench	Zinc plated steel Code	Stainless steel AISI 304 Code	Stainless steel AISI 316 Code	Max static load (N)
M8x1,25	72	45	6	27 / 7412	27 / 7413	-	12000
	92	65	6	27 / 7414	27 / 7415	-	
	134	107	6	27 / 7900	27 / 7901	-	
M10x1,5	64	35	8	27 / 7416	27 / 7417	-	13000
	99	70	8	27 / 7418	27 / 7419	-	
	144	115	8	27 / 7420	27 / 7421	-	
M12x1,75	74	43	10	27 / 7422	27 / 7423	-	14000
	94	63	10	27 / 7424	27 / 7425	-	
	109	77	10	27 / 7426	27 / 7427	-	
	124	93	10	27 / 7428	27 / 7429	27 / 85171	
	154	123	10	27 / 7430	27 / 7431	-	
M14x2	94	61	12	27 / 7432	27 / 7433	-	15000
	124	91	12	27 / 7434	27 / 7435	-	
	149	116	12	27 / 7890	27 / 7891	-	
	198	165	12	27 / 86788	27 / 86791	-	
	95	60	13	27 / 7436	27 / 7437	27 / 85172	
M16x2	125	90	13	27 / 7438	27 / 7439	-	17000
	140	105	13	27 / 7440	27 / 7441	-	
	160	125	13	27 / 7442	27 / 7443	27 / 85173	
	190	155	13	27 / 7444	27 / 7445	-	
	200	165	13	27 / 7446	27 / 7447	-	
	240	205	13	27 / 83158	27 / 83159	-	
M20x2,5	125	86	17	27 / 7448	27 / 7449	-	19000
	155	116	17	27 / 7450	27 / 7451	-	
	180	141	17	27 / 7452	27 / 7453	27 / 85174	
	200	161	17	27 / 88842 NEW	27 / 88843 NEW	-	
	237	198	17	27 / 7454	27 / 7455	-	

Spindle measures in inches				Spindle material			
ød	A	H	Wrench	Zinc plated steel Code	Stainless steel AISI 304 Code	Max static load (N)	
1/2"-13 UNC	5,24"	4"	7/16"	27 / 83276	27 / 83277	14000	
5/8"-11 UNC	8,38"	7"	1/2"	27 / 83278	27 / 83279	17000	
3/4"-10 UNC	8,47"	7"	5/8"	27 / 83280	27 / 83281	19000	

Base material: Reinforced polyamide black colour.

Box quantity: 24 pieces.

Accessories

Anti-slip pads:

- code: 7632;
- material: thermoplastic rubber 68 Shore black colour;
- box quantity: 24 pieces.

Washers UNI 6592-69 - Box quantity: 24 pieces.

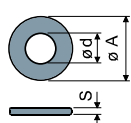
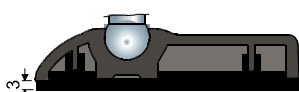

ø M	M8	M10	M12	M14	M16	M20
Smm	1,6	2	2,5	2,5	3	3
ø A mm	17	21	24	28	30	37
Zinc plated steel codes	7636	7283	7284	7285	7289	7290
Stainless steel codes	7637	7286	7287	7288	7291	7292

Nuts UNI 5588-65 - Box quantity: 24 pieces.

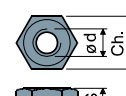

ø d	M8	M10	M12	M14	M16	M20
Smm	6,5	8	10	11	13	16
Ch. mm	13	17	19	22	24	30
Zinc plated steel codes	7634	7269	7270	7271	7275	7276
Stainless steel codes	7635	7272	7273	7274	7277	7278

On request

- **Bases:** In reinforced polypropylene (maximum static load is reduced to 1/3 compared to that with polyamide base) • other colours.
- **Spindles with:** Sunk hexagon head • second wrench seat head • hexagon wrench seat • threads with other pitches and lengths.
- **Box quantity:** Not standard.
- **Assembling of:** Anti-slip pads • nuts • washers.

Thread sizes in inches are expressed as the number of threads (UNC coarse thread) per Imperial inch