

Accessories for supporting and levelling components

Part. 104 Spacer (for Part.92, 93)

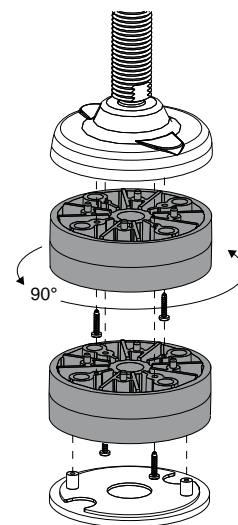
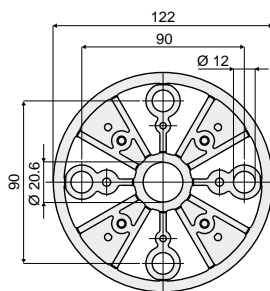
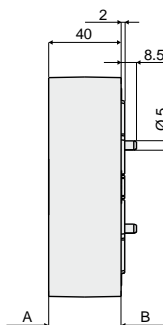
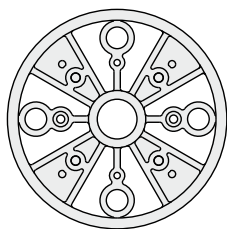

Example of application

Code
104 / 83410

A view (spacer)

B view (spacer)

Materials: Spacer in reinforced polyamide black colour.

Features: To be used with foot-plates part. 92 and 93 to increase the height of the foot-plates. It is possible to assemble the anti-slip code 7633 (see page 259, 264).

Box quantity: 8 pieces.

On request:

- Box quantity: According to your request.

Part. 127 Spacer (for Part.25)

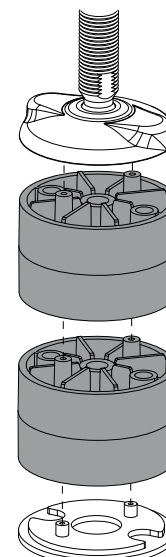
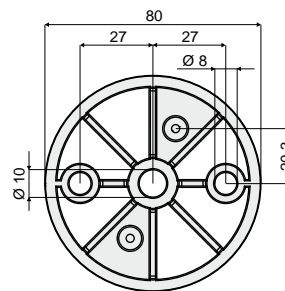
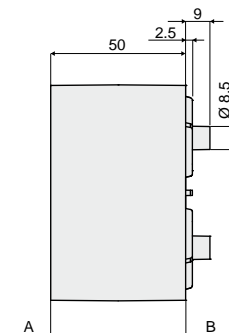
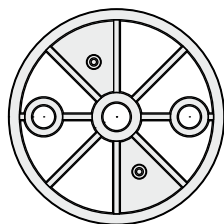

Example of application

Code
127 / 86797

A view (spacer)

B view (spacer)

Materials: Spacer in reinforced polyamide black colour.

Features: To be used with footplate part. 25 to increase the height of the foot-plates. It is possible to assemble the anti-slip code 7266 (see page 250, 256).

Box quantity: 8 pieces.

On request:

- Box quantity: According to your request.

Part. 128 Protection cap (for M20 spindle)

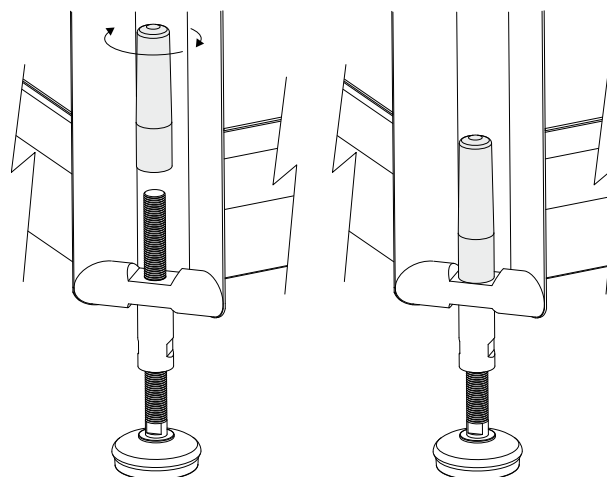
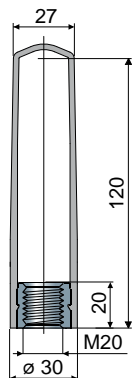
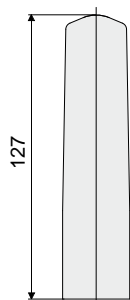

Example of application

Code
128 / 87128

Materials: Cap in polypropylene grey colour, threaded bushing in nickel plated brass.

Features: To be screwed as a thread protection on M20 spindles, for total protection of the thread.

Box quantity: 8 pieces.

On request:

- Box quantity: According to your request.