

Adjustable feet

(base in steel)

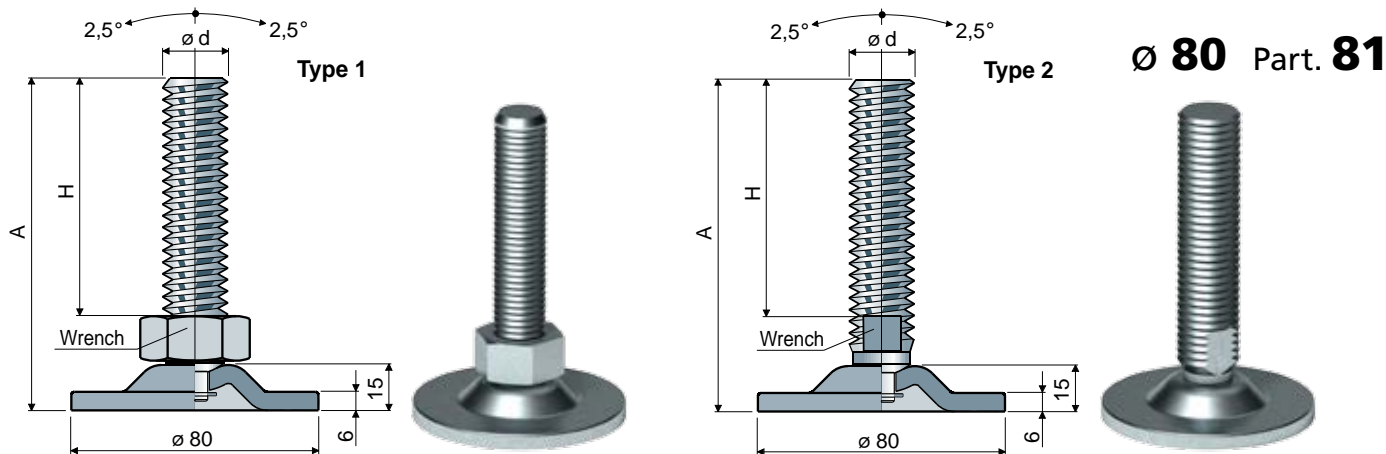

Ø 80 Part. 81

Spindle measures in mm			Spindle and base in zinc plated steel			Max static load (N)
$\varnothing d$	A	H	Wrench	Type 1 Code	Type 2 Code	
M20x2,5	120	87	30	81 / 80786	-	40000
	152	117	30	81 / 84318	-	
	160	127	30	81 / 82882	-	
M24x3	120	85	19	-	81 / 80214	

Material: Base and spindle in zinc-plated steel.

Box quantity: 8 pieces.

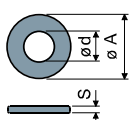
Washers UNI 6592-69 - Box quantity: 24 pieces.



$\varnothing M$	M20	M24
Smm	3	4
$\varnothing A$ mm	37	44
Zinc plated steel codes	7290	7293

Nuts UNI 5588-65 - Box quantity: 24 pieces.

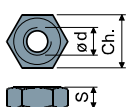

$\varnothing d$	M20	M24
Smm	16	19
Ch. mm	30	36
Zinc plated steel codes	7276	7279

On request

- Spindles with: Sunk hexagon head • second wrench seat head • hexagon wrench seat • threads with other pitches and lengths.
- Box quantity: Not standard.
- Assembling of: Nuts • washers.

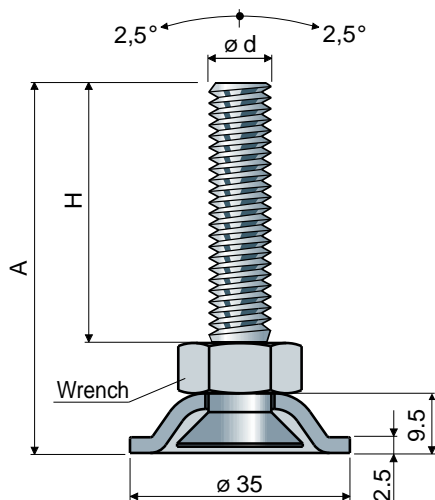
Ø 35 Part. 123

Spindle measures in mm			Spindle material			Max static load (N)
$\varnothing d$	A	H	Wrench	Zinc plated steel Code	Stainless steel AISI 304 Code	
M10x1,5	66	48,5	17	123 / 85712	123 / 85713	10000
	91	73,5	17	123 / 85714	123 / 85715	
	121	103,5	17	123 / 85716	123 / 85717	

Base material: Stainless steel AISI 304.

Box quantity: 24 pieces.

On request

- Box quantity: Not standard.
- Assembling of: Nuts • washers.