

Adjustable feet

(base in steel)

∅ 113 Part. 98

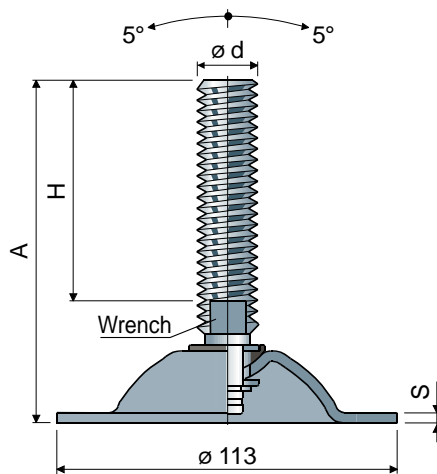

Spindle measures in mm			Spindle and base material			
∅ d	A	H	Wrench	Zinc plated steel Code	Stainless steel AISI 304 Code	Max static load (N)
M16x2	100	58	13	98 / 7584	98 / 7585	15000 (zinc plated) S = 3,5
	131	89	13	98 / 89306 NEW	98 / 89313 NEW	
	161	119	13	98 / 7918	98 / 7919	
	187	145	13	98 / 7586	98 / 7587	
	243	201	13	98 / 7588	98 / 7589	
M18x2,5	199	157	15	98 / 82140	98 / 82141	
	134	89	17	98 / 87324	98 / 87325	
	152	107	17	98 / 7590	98 / 7591	
M20x2,5	181	136	17	98 / 7592	98 / 7593	
	202	157	17	98 / 7594	98 / 7595	
	235	190	17	98 / 83238	98 / 83239	
	283	238	17	98 / 83240	98 / 83241	
	M24x3	138	90	19	98 / 7596	98 / 7597
175		127	19	98 / 7598	98 / 7599	
210		162	19	98 / 7600	98 / 7601	
250		202	19	98 / 83242	98 / 83243	
M30x3,5	173	125	24	98 / 7602	98 / 7603	
	233	185	24	98 / 7604	98 / 7605	

Box quantity: 8 pieces.

Washers UNI 6592-69 - Box quantity: 24 pieces.

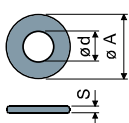

∅ M	M16	M20	M24	M30
Smm	3	3	4	4
∅ A mm	30	37	44	56
Zinc plated steel codes	7289	7290	7293	7295
Stainless steel codes	7291	7292	7294	7296

Nuts UNI 5588-65 - Box quantity: 24 pieces.

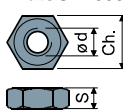

∅ d	M16	M20	M24	M30
Smm	13	16	19	24
Ch. mm	24	30	36	46
Zinc plated steel codes	7275	7276	7279	7281
Stainless steel codes	7277	7278	7280	7282

On request

- Spindles with: Sunk hexagon head • second wrench seat head • hexagon wrench seat • threads with other pitches and lengths • stainless steel AISI 316.
- Box quantity: Not standard.
- Assembling of: Nuts • washers.