

Adjustable feet

(base in nickel plated steel)

Ø 80 Part. 95

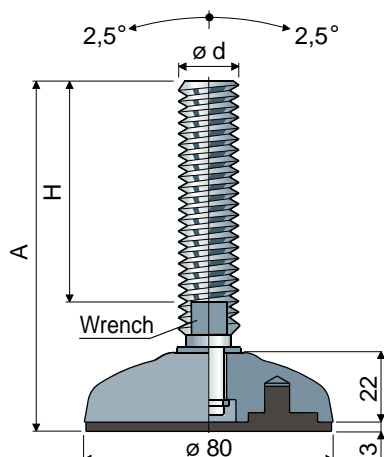

Spindle measures in mm				Spindle material		Max static load (N)
Ø d	A	H	Wrench	Zinc plated steel Code	Stainless steel AISI 304 Code	
M16x2	101	58	13	95 / 7532	95 / 7533	46000
	132	89	13	95 / 89310 NEW	95 / 89317 NEW	
	162	119	13	95 / 7910	95 / 7911	
	188	145	13	95 / 7534	95 / 7535	
	244	201	13	95 / 7536	95 / 7537	
M18x2,5	200	157	15	95 / 82144	95 / 82145	47000
	135	89	17	95 / 87328	95 / 87329	
M20x2,5	153	107	17	95 / 7538	95 / 7539	47000
	182	136	17	95 / 7540	95 / 7541	
	203	157	17	95 / 7542	95 / 7543	
	236	190	17	95 / 83244	95 / 83245	
	284	238	17	95 / 83246	95 / 83247	
M24x3	139	90	19	95 / 7544	95 / 7545	48000
	176	127	19	95 / 7546	95 / 7547	
	211	162	19	95 / 7548	95 / 7549	
	250	202	19	95 / 83248	95 / 83249	

Base material: Nickel plated steel.

Box quantity: 8 pieces.

Features: The feet are complete with anti-slip pad made out of thermoplastic rubber 68 Shore black colour.

Washers UNI 6592-69 - Box quantity: 24 pieces.

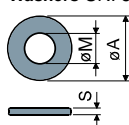

Ø M	M16	M20	M24
Smm	3	3	4
Ø A mm	30	37	44
Zinc plated steel codes	7289	7290	7293
Stainless steel codes	7291	7292	7294

Nuts UNI 5588-65 - Box quantity: 24 pieces.

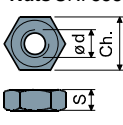

Ø d	M16	M20	M24
Smm	13	16	19
Ch. mm	24	30	36
Zinc plated steel codes	7275	7276	7279
Stainless steel codes	7277	7278	7280

On request

- Spindles with: Sunk hexagon head • second wrench seat head • hexagon wrench seat • threads with other pitches and lengths • stainless steel AISI 316.
- Box quantity: Not standard.
- Assembling of: Nuts • washers.