

# Adjustable feet (base in painted steel)

Part. **129**  $\varnothing$  **160**

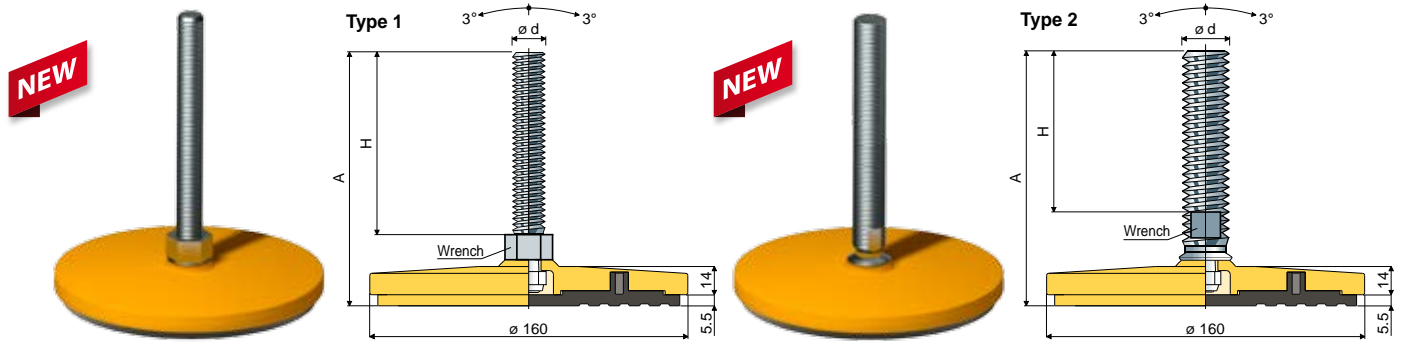

Spindle measures in mm				Spindle in zinc plated steel		Spindle in stainless steel		Max static load (N)
ø d	A	H	Wrench	Type 1 Code	Type 2 Code	Type 1 Code	Type 2 Code	
M16x2	95	57	24	129 / 88760	-	129 / 88769	-	50000
	127	89	24	129 / 89318	-	129 / 89327	-	
	156	118	24	129 / 88762	-	129 / 88763	-	
	182	144	24	129 / 88764	-	129 / 88765	-	
	238	200	24	129 / 88766	-	129 / 88767	-	
M20x2,5	135	89	17	-	129 / 88770	-	129 / 88771	
	153	107	17	-	129 / 88772	-	129 / 88773	
	182	136	17	-	129 / 88774	-	129 / 88775	
	203	157	17	-	129 / 88776	-	129 / 88777	
	236	190	17	-	129 / 88778	-	129 / 88779	
M24x3	284	238	17	-	129 / 88780	-	129 / 88781	
	138	90	19	-	129 / 88782	-	129 / 88783	
	175	127	19	-	129 / 88784	-	129 / 88785	
	210	162	19	-	129 / 88786	-	129 / 88787	
M30x3,5	250	202	19	-	129 / 88788	-	129 / 88789	
	173	125	24	-	129 / 88790	-	129 / 88791	
	233	185	24	-	129 / 88792	-	129 / 88793	

Base material: Painted steel, yellow colour, Ral 1007.

Box quantity: 8 pieces.

Features: Complete with anti-slip pad made out of thermoplastic rubber 70 Shore black colour.

## Adjustable feet, sanitizable (stainless steel base for important loads)

Part. **115**  $\varnothing$  **78**

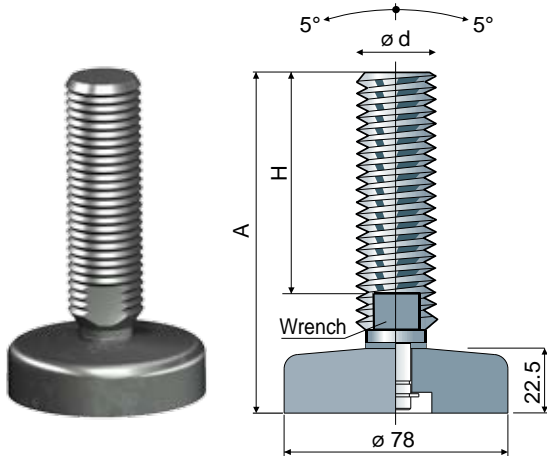

Spindle measures in mm				Spindle and base in stainless steel AISI 304 Code	Max static load (N)
ø d	A	H	Wrench		
M16x2	99	58	13	115 / 83958	52000
	130	89	13	115 / 89320 <b>NEW</b>	
	160	119	13	115 / 83959	
	186	145	13	115 / 83960	
	242	201	13	115 / 83961	
M20x2,5	132	89	17	115 / 87334	
	150	107	17	115 / 83962	
	179	136	17	115 / 83963	
	200	157	17	115 / 83964	
	233	190	17	115 / 83965	
M24x3	281	238	17	115 / 83966	
	136	90	19	115 / 83967	
	173	127	19	115 / 83968	
	208	162	19	115 / 83969	
M30x3,5	248	202	19	115 / 83970	
	171	125	24	115 / 83971	
	231	185	24	115 / 83831	

Material: Spindle and base in stainless steel AISI 304.

Box quantity: 8 pieces.

Washers UNI 6592-69 - Box quantity: 24 pieces.

ø M	M16	M20	M24	M30
Smm	3	3	4	4
ø A mm	30	37	44	56
Stainless steel codes	7291	7292	7294	7296

Nuts UNI 5588-65 - Box quantity: 24 pieces.

ø d	M16	M20	M24	M30
Smm	13	16	19	24
Ch. mm	24	30	36	46
Stainless steel codes	7277	7278	7280	7282

On request

- Spindles with: Sunk hexagon head • second wrench seat head • hexagon wrench seat • threads with other pitches and lengths • stainless steel AISI 316.
- Box quantity: Not standard.
- Assembling of: Nuts • washers.