

Adjustable feet, sanitizable with side fixing system

(base in stainless steel)

65x96 Part. 119

Type 1							
Spindle measures in mm				Spindle and base in stainless steel AISI 304			
ød	A	H	Wrench	Black	White	Blue Ral 5005	Max static load (N)
				anti-slip pad	anti-slip pad	anti-slip pad	
				Code	Code	Code	
M12x1,75	110	70	17	119 / 84819	119 / 85914	119 / 88216	22000
M14x2	148	108	12	119 / 84820	119 / 85915	119 / 88217	
	102	58	13	119 / 84821	119 / 85916	119 / 88218	
	133	89	13	119 / 89334 NEW	119 / 89335 NEW	119 / 89336 NEW	
M16x2	163	119	13	119 / 84822	119 / 85917	119 / 88219	
	189	145	13	119 / 84823	119 / 85918	119 / 88220	
	245	201	13	119 / 84824	119 / 85919	119 / 88221	
M18x2,5	201	157	15	119 / 84825	119 / 85920	119 / 88222	
	133	89	17	119 / 87347	119 / 87348	119 / 88223	
	151	107	17	119 / 84826	119 / 85921	119 / 88224	
M20x2,5	180	136	17	119 / 84827	119 / 85922	119 / 88225	
	201	157	17	119 / 84828	119 / 85923	119 / 88226	
	234	190	17	119 / 84829	119 / 85924	119 / 88227	
	282	238	17	119 / 84830	119 / 85925	119 / 88228	

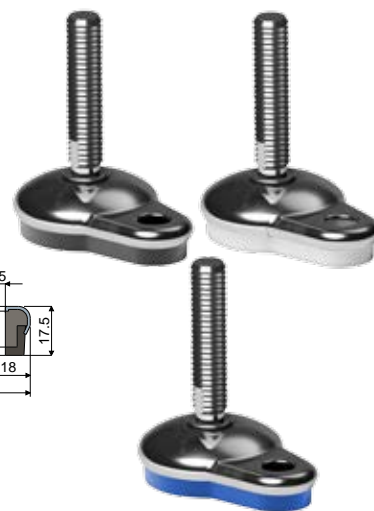
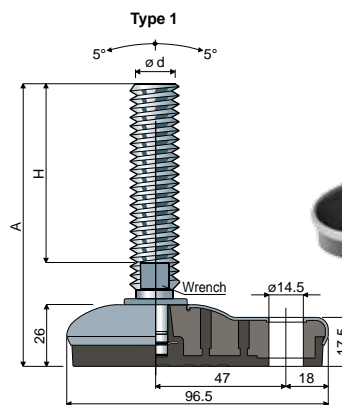

Base material: Internal part made of reinforced polyamide; external covering made of stainless steel AISI 304; anti-slip pad made of thermoplastic rubber 68 Shore black, white or blue Ral 5005 colour.

Box quantity: 8 pieces.

Features: Co-moulded anti-slip pad allows a perfect adherence with steel base. Consequent absence of internal cavities makes foot extremely cleanable. The threaded insert guarantees the protection of the spindle thread. Feet with M12 spindle diameter are supplied with hexagonal adjustment for 17 mm. wrench.

Washers UNI 6592-69 - Box quantity: 24 pieces.

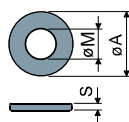

ø M	M12	M14	M16	M20	M24	M30
Smm	2,5	2,5	3	3	4	4
ø A mm	24	28	30	37	44	56
Stainless steel codes	7287	7288	7291	7292	7294	7296

Nuts UNI 5588-65 - Box quantity: 24 pieces.

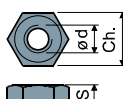

ø d	M12	M14	M16	M20	M24	M30
Smm	10	11	13	16	19	24
Ch. mm	19	22	24	30	36	46
Stainless steel codes	7273	7274	7277	7278	7280	7282

On request

- Spindles with: Sunk hexagon head • second wrench seat head • hexagon wrench seat • threads with other pitches and lengths • stainless steel AISI 316.
- Box quantity: Not standard.
- Assembling of: Nuts • washers.

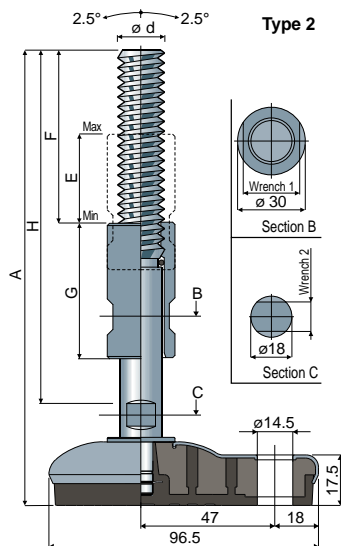

Type 2											
Spindle measures in mm					Spindle and base in stainless steel AISI 304						
ød	A	H	F	E	G	Wrench 1	Wrench 2	Black	White	Blue Ral 5005	Max static load (N)
								anti-slip pad	anti-slip pad	anti-slip pad	
								Code	Code	Code	
M16x2	200	159	73	39	60	22	12	119 / 88032	119 / 88034	119 / 88229	22000
	260	220	100	78	100	22	12	119 / 88033	119 / 88035	119 / 88230	
M20x2,5	200	159	73	39	60	25	13	119 / 85088	119 / 85926	119 / 88231	
	260	220	100	78	100	25	13	119 / 85089	119 / 85927	119 / 88232	
M24x3	200	159	73	39	60	30	17	119 / 88036	119 / 88038	119 / 88233	
	260	220	100	78	100	30	17	119 / 88037	119 / 88039	119 / 88234	